



**Congratulations** on your purchase of the LED-Wiz+GP™ with LumAura™ Technology, one of the most feature packed, USB-compatible, LED and Output/ Gamepad-type control interfaces available today....and the best value! **CAUTION: This unit has been factory tested and is intended for professional installation. IDVT Inc. will not be responsible for any damages that occur, either directly or indirectly, as a result of using of this device for any purpose.**

**Installation:**

Making sure the bottom of the PCB is not in contact with any conductive materials, plug the B side of the supplied USB cable into the port of the LED-Wiz+GP™ and then plug the A side into the USB port on the PC. Due to the power requirements of the device, connection to a non-powered hub is not recommended unless the outputs are powered from the PC power supply. If this is the first time you have installed a USB HID Device, you may need the install disc for your OS. Follow the on-screen steps during the installation procedure provided by your OS. When completed, you may need to reboot. The LED-Wiz+GP™ will be identified as an "HID Compliant Game Controller" and should be listed in the "Human Interface Devices" list under your systems "Hardware Manager."

**Mounting:**

Mounting standoffs are **required** and included with your purchase. You **must** ensure that the bottom of the PCB is not in contact with any conductive materials and that the heads of your fasteners are small enough that they do not make contact with any components on the PCB.

**Screw Terminals**

The LED-Wiz+GP™ provides for simple wire connection to the PCB through the use of "screw terminal blocks." With the device **disconnected from power**, simply strip approximately 3/16" of insulation from one end of your wire, insert the bare end into the terminal associated with the desired output for your device, and tighten the screw with a small screwdriver. Do not over tighten, but be sure that the wire cannot be pulled from the connector by giving it a firm tug after tightening. Also be sure that no strands of wire are outside of the terminal that might cause a short circuit to adjacent connections.

**Input Connections**

The first thing that should be done is to connect a wire from the ground terminal to the first switch in your chain. Then connect a wire from the same switch terminal you hooked the first one to, to one of the terminals of an adjacent switch. Repeat this until all switches are connected together with the ground wire, or "daisy-chained." After that, connect the normally open contact of your switch to the desired **INPUT** on the LED-WIZ+GP. Do this for the switches on all controls you wish to use. Refer to Figure 4. for an example.

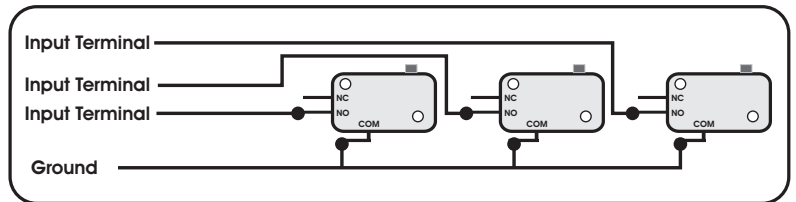

**Output Connections:**

The output drivers used with the LED-Wiz+GP™ are technically capable of handling up to 50v at 500ma per output. However, as the LED-Wiz+GP is not designed to handle the maximums possible as a result of driving every output at its fullest potential, it is ultimately up to the user to decide what is **prudent** and **safe** when deciding how to use the LED-Wiz in their application.

This new version of the LED-Wiz+GP PCB has been designed to allow direct access to the suppression diodes of the output driver chips on a per chip, or "8-output bank", basis. This gives the user the capability of running inductive loads (relays, coils, solenoids, etc) with as many as 4 different voltages per board. The positive power line must *never* be connected to any other part of the LED-Wiz+GP board, and all devices attached to any bank of outputs must share the same voltage requirements. For operating only LED's, it may not be necessary to be concerned with the "Bank Voltage Select" terminals at all. However, any inductive loads (or loads which you can't identify as inductive or not) **must** have the positive voltage line connected to the appropriate "Bank Voltage Select" terminal for the output bank which the negative lines of the devices have been connected. In cases where only one device voltage is being used, it is permissible to simply link all of the "Bank Voltage Select" terminals together and then connect them to the positive line of the power supply. This configuration was the default state of the original LED-Wiz+GP when shipped. Note: If this section is not understood by the user, it is highly recommended that an email be sent to [techsupport@groovygamegear.com](mailto:techsupport@groovygamegear.com) for clarification. **Improperly connecting positive voltages to the LED-Wiz+GP will result in destruction of the LED-Wiz+GP, and quite likely any devices attached..including your computer! So be safe and ask questions if necessary!**

If only the USB port power is to be used to power external devices, be aware that it can supply only 5v DC power with a total current delivery of about 500ma. Larger 5v DC loads, like small incandescent lamps and relays, or large numbers of LEDs, should be connected to the PC Power supply (Figure 2) through a cable with an **in-line fuse**. The use of a fuse is **strongly** recommended! This type of fused cable is not included but can be purchased at your local electronics store. Be sure to select the proper fuse size for the load you have connected to the device! Too large a fuse and it won't protect anything, too small and they will keep blowing. Keep all of your wiring clean and tidy. The most important thing to keep in mind when wiring your project is **safety first** and a well thought out approach will help ensure this. See the diagrams below, and on the back of this page, for wiring examples.

Many excellent third party applications and plug-ins are available from the web, as well as OCX and DLL controls for adding LED-Wiz support to your own software.

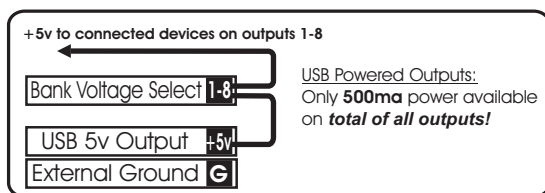

FIGURE 1. Power to external devices provided by USB Port.

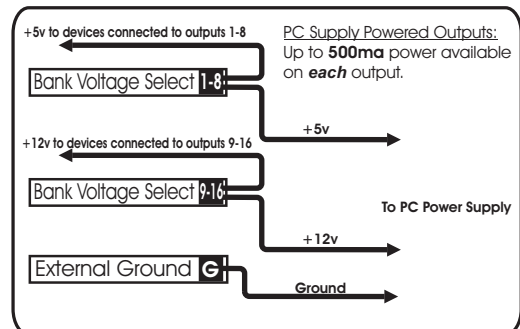

FIGURE 2. Power to external devices provided by PC Power Supply.

**LED Usage Considerations:**

LED's are like goldfish. They don't know when to stop consuming and will "pop" if you feed them too much. For this reason, you **must** install a resistor in series with the LED to limit the current to an amount that will make the LED bright and happy.

Resistor values for use with LEDs connected to the LED-WIZ can be found using the following formula:

$$\text{RESISTOR VALUE} = (5\text{v} - \text{LED VOLTAGE}) / \text{LED CURRENT}$$

So, the resistor value for an 3.2v LED with a 20ma current rating would be 100ohms and the formula would be:

$$R = (5-3.2) / .020 \text{ or } R=1.8 / .020 \text{ or } R= 90\text{ohms.}$$

So where did the 100ohm resistor come from? Simple. Resistors are not commonly available in all values, so it may be necessary to use the next closest value. **Always use the next higher value, not the next lower one.** It is always acceptable to use a higher resistor value for a slightly dimmer LED, but lower than proper values will damage the LED, resulting in poor performance and a much shorter life span.

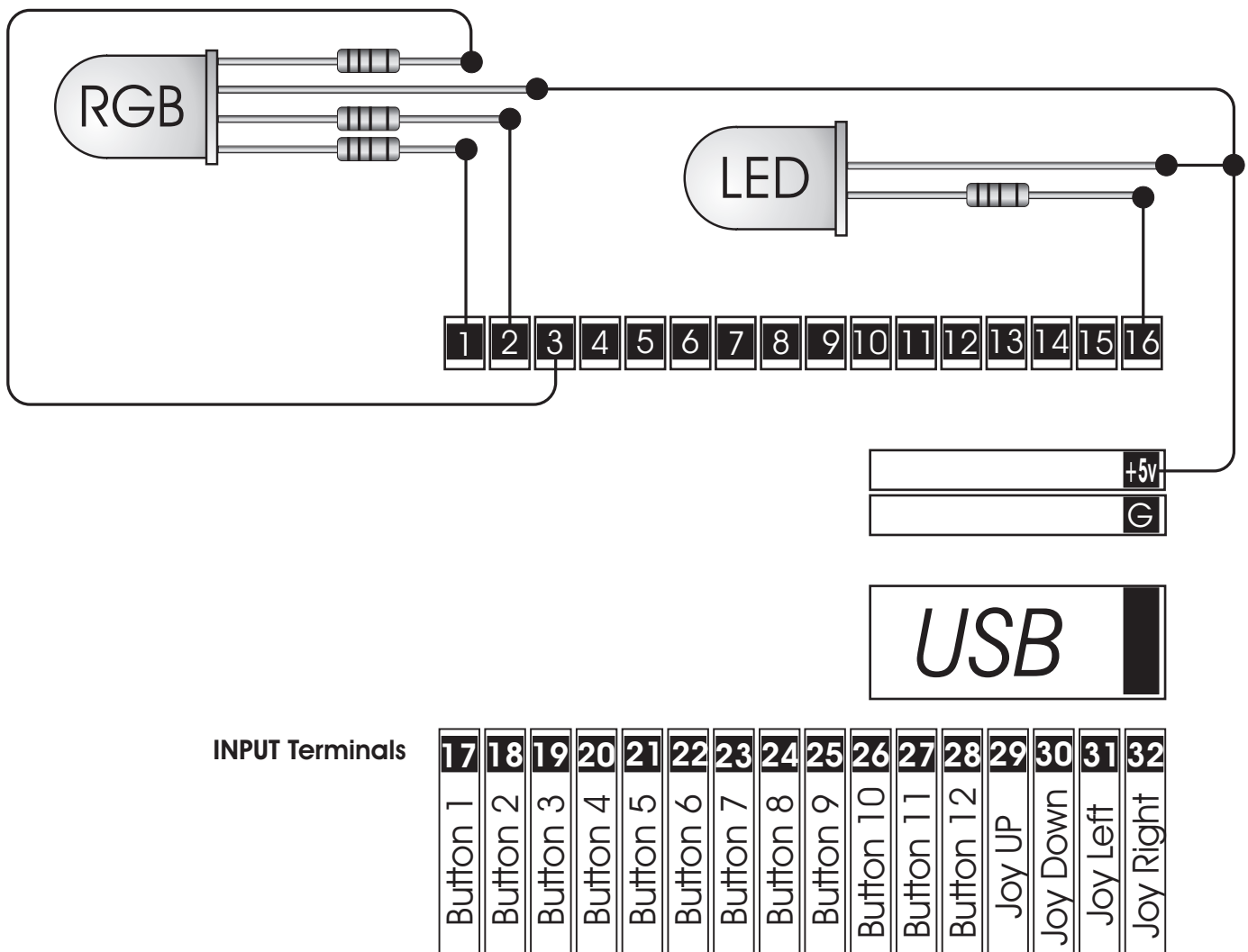

**FIGURE 3. Example showing proper wiring of an RGB and Standard LED on OUTPUT side, and game controller assignments on INPUT side.**